



CARSON CITY HEALTH & HUMAN SERVICES  
 900 E. Long Street, Carson City, NV 89706  
 (775) 887-2190 – Fax (775) 887-2248

## Food Vending at Temporary Events

As of March 19, 2008, Carson City Environmental Health Department has updated the requirements for food vendors at temporary events. Included in this packet are: the **MINIMUM** requirements that must be followed, food safety tips, and an application for a health permit.

1. All vendors seeking a temporary health permit for a special event **MUST** have a temporary Carson City Business License. To obtain this license, please contact the business licensing office at (775) 887-2105 prior to applying for your temporary food permit. **You may need at least 14 business days to obtain this permit.**
2. Temporary health permit applications must be received by CCHHS **at least 5 working days prior to the event.** All fees (listed below) must be paid prior to application review and approval to operate.
3. Late fees will be assessed on all applications received less than 5 working days prior to the event.

Event Duration	Event Fee	Late Fee
1 day	\$25.00	\$25.00
2-7 days	\$50.00	\$35.00
8-14 days	\$75.00	\$40.00
Farmer's Market	\$75.00	\$40.00

*Non-profit organizations which provide a non-profit tax id# and Food Establishments operating under a current Carson City Health Permit are not charged Event Fees. Late fees will be assessed on all late applications.*

**NOTE: HEALTH INSPECTORS CANNOT COLLECT FEES IN THE FIELD**

4. **It is your responsibility to contact CCHHS at (775) 887-2190 to ensure that we have received your permit application.**
5. Please complete the entire application packet including the bottom portion. Incomplete applications will cause a delay in the review process and may prohibit you from operating a temporary food service at the event.
6. Once an application is complete, an environmental health inspector will conduct a routine inspection of your temporary food booth at the start of the event. If the inspector determines the food booth is in compliance with temporary food vending requirements, you will be issued your health permit to operate. You will receive a yellow copy to serve as your temporary health permit.
7. Please post the permit copy in a conspicuous, observable place for the duration of the event. If you have submitted your application on time and been given an approval, you will be allowed to operate before receiving your copy of the permit.
8. **YOU WILL NOT BE ALLOWED TO OPERATE**, if upon inspection we do not have your permit for operation and/or your temporary food booth is not in compliance with the temporary food service regulations. You are expected to know and comply with the temporary food vending regulations provided in this packet. **FAILURE TO COMPLY WILL RESULT IN LOSS OF THE PERMIT AND PRIVILEGES TO OPERATE AT THE SPECIAL EVENT.**

## Minimum Requirements for Food Preparation and Handling

1. Food booths must have an overhead structure, and an acceptable floor surface approved by the health authority.
2. Foods (including ice) must be from an approved source, i.e., restaurant/grocery store/a source approved by the health authority. Food prepared in a private residence is **strictly prohibited**.
3. Potentially hazardous foods served at a temporary food establishment must be prepared and served in the same day and must not be saved for service on the following day.
4. Minimum cooking temperatures required are as follows:
  - a. Chicken and Hot Dogs 165 degrees Fahrenheit (°F)
  - b. Ground Beef: 155 degrees
  - c. Pork: 155 degrees
  - d. All other foods: 140 degrees
5. Any raw meats or poultry must be stored and prepared so they will not contaminate other foods.
6. Hot foods must be held at 140°F or greater. **Chafing dishes are not allowed** for hot holding at outdoor events. Gas or electric hot holding units are required.
7. Heating or cooking equipment must be placed in an area inaccessible to the public.
8. All foods that require reheating must be quickly and thoroughly heated to 165 °F within 30 minutes prior to being held or served.
9. Foods that require cold storage must be held at 40°F or below.
10. A metal stem thermometer is required at each food booth handling any potentially hazardous foods (i.e. raw meats, hot dogs, chili, potatoes, rice, beans, etc.). The thermometer should have a range of at least 0°F to 220°F and accurate to  $\pm 2^\circ\text{F}$
11. A hand wash station is required at each food booth. A minimum of two gallons of water dispensed by a spigot, pump soap (bar soap is not acceptable), paper towels and a catch basin/bucket (for gray water).
12. Cloth sanitizing towels used during the event must be stored in sanitizing bucket with proper mix of 100 parts per million (ppm) of chlorine solution. Place approximately one tablespoon of bleach per gallon of water.
13. Food service utensils must be washed, rinsed and sanitized in a three-compartment sink, another approved method or an adequate supply of clean utensils must be available for daily operations.
14. All food and paper products must be stored off the ground.
15. Condiments must be dispensed from a pump or served in single-service packets.
16. Booths that offer food samples must serve individual portions so that contact with food products is minimized (i.e. on individual plates or with toothpicks). Common bowls are strictly prohibited.
17. Baked goods must be displayed under a cover or in a display case. Baked goods will be served with tongs or other devices that minimize or eliminate human contact.
18. An ice scoop with a handle must be used to serve ice to customers. The scoop must be stored in an upright position so that the handle does not come into contact with ice. Ice or ice products may not be exposed to sources of contamination.
19. Suitable dispensing utensils, adequate in number, must be used when serving food. Utensils must be stored in the food with the handle of the utensil extended out of the food.
20. Solid waste and garbage must be stored in a leak proof container with tight fitting lids.
21. All liquid waste must be contained and disposed of in a sanitary sewer.

## **Hand Washing and Other Food Safety Quick Tips**

### **WASHING YOUR HAND IS NOT HARD TO DO!**

Good personal hygiene is a critical protective measure against food borne illness. In addition, customers frequently judge a food service operation by observing the personnel serving them.

### **WASH YOUR HANDS FOR AT LEAST 20 SECONDS.**

This is usually the length of time it takes to sing "Happy Birthday"

### **WHEN TO WASH YOUR HANDS:**

- Before handling any foods
- Before putting on gloves
- After handling raw foods and before handling foods that will require further cooking.
- After smoking, touching your face, hair or contact with body fluids or using the restroom

### **ALL PERSONNEL HANDLING FOODS SHOULD BE VISIBLY HEALTHY AND NOT HAVE:**

- Colds and/or Coughs
- Diarrhea or Stomach Flu

### **ALL PERSONNEL SHOULD BE DRESSED APPROPRIATELY FOR SERVING FOOD**

- Wear clean clothing and adequate hair restraints
- No jewelry, watches, rings, bracelets, or finger nail polish
- No smoking or eating while handling food or in the food prep area

### **SANITATION OF YOUR WORK AREA**

- Always keep a clean, sanitary work environment
- Frequently clean counter, equipment and all work surfaces with sanitizing solution
- To clean food prep areas: keep wiping cloths in a bucket of clean water with bleach (about 1 tablespoon per gallon of water)
- Keep food serving utensils in a container of bleach solution and change solution frequently

### **FOOD SAFETY TIPS**

- Potentially Hazardous foods are those that support the rapid growth of organisms that cause food borne illness. Such foods include: meats, melons, dairy products, gravies, rich, potatoes and beans
- Pre-processed, pre-cooked foods that are ready-to-serve and individually wrapped or sealed, are best for temporary food booths
- Keep all unsealed foods protected from insects – especially from flies. Keep lids on all serving dishes or saran wrap on all containers without lids

**This is only a partial list of the requirements for temporary food establishments and shall not be construed to be exclusive. To specifically determine individual needs, please contact Carson City Health & Human Services at (775) 887-2190.**

# Booth Set-up Diagrams

Sample Canopy Set-up

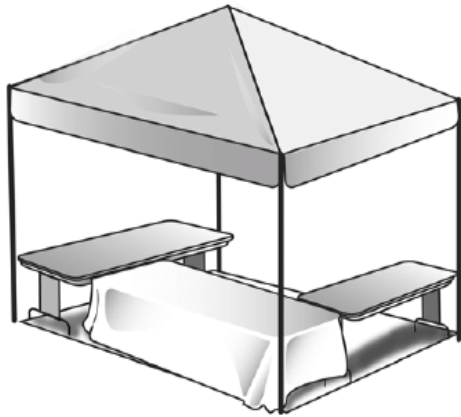

Sample Minimum Hand Wash Set-up

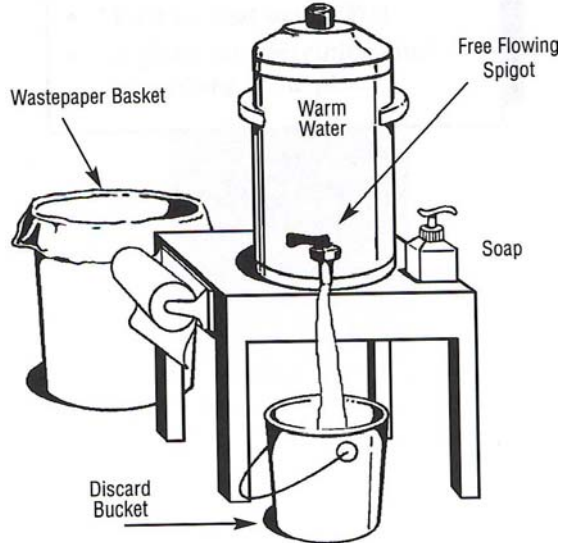

Sample of suggested set up under canopy

